



OPERATING INSTRUCTIONS

EN

Translation of the Original

CCT 361 | 362 | 363 | 364 | 365

Digital capacitive gauge

PFEIFFER  **VACUUM**



Dear Customer,

Thank you for choosing a Pfeiffer Vacuum product. Your new gauge is designed to support you in your individual application with maximum performance and without malfunctions. The name Pfeiffer Vacuum stands for high-quality vacuum technology, a comprehensive and complete range of top-quality products and first-class service. From this extensive, practical experience we have gained a large volume of information that can contribute to efficient deployment and to your personal safety.

In the knowledge that our product must avoid consuming work output, we trust that our product can offer you a solution that supports you in the effective and trouble-free implementation of your individual application.

Please read these operating instructions before putting your product into operation for the first time. If you have any questions or suggestions, please feel free to contact info@pfeiffer-vacuum.de.

Further operating instructions from Pfeiffer Vacuum can be found in the [Download Center](#) on our website.

Disclaimer of liability

These operating instructions describe all models and variants of your product. Note that your product may not be equipped with all features described in this document. Pfeiffer Vacuum constantly adapts its products to the latest state of the art without prior notice. Please take into account that online operating instructions can deviate from the printed operating instructions supplied with your product.

Furthermore, Pfeiffer Vacuum assumes no responsibility or liability for damage resulting from the use of the product that contradicts its proper use or is explicitly defined as foreseeable misuse.

Copyright

This document is the intellectual property of Pfeiffer Vacuum and all contents of this document are protected by copyright. They may not be copied, altered, reproduced or published without the prior written permission of Pfeiffer Vacuum.

We reserve the right to make changes to the technical data and information in this document.



Table of contents

1	About this manual	7
1.1	Validity	7
	1.1.1 Applicable documents	7
	1.1.2 Variants	7
1.2	Target group	8
1.3	Conventions	8
	1.3.1 Instructions in the text	8
	1.3.2 Pictographs	8
	1.3.3 Stickers on the product	8
	1.3.4 Abbreviations	9
1.4	Trademark proof	9
2	Safety	10
2.1	General safety information	10
2.2	Safety instructions	10
2.3	Safety precautions	12
2.4	Proper use	13
2.5	Foreseeable improper use	13
2.6	Responsibilities and warranty	13
2.7	Owner requirements	13
2.8	Personnel qualification	13
	2.8.1 Ensuring personnel qualification	14
	2.8.2 Personnel qualification for maintenance and repair	14
	2.8.3 Advanced training with Pfeiffer Vacuum	14
2.9	Operator requirements	15
3	Product description	16
3.1	Function	16
3.2	Button and status display	16
3.3	Identifying the product	16
3.4	Scope of delivery	16
4	Transport and storage	17
4.1	Transporting the product	17
4.2	Storing the product	17
5	Installation	18
5.1	Establish vacuum connection	18
5.2	Establish "RS-485" connection	19
6	Interfaces	21
6.1	Interface RS-485	21
6.2	Pfeiffer Vacuum protocol for RS-485 interface	22
	6.2.1 Telegram frame	22
	6.2.2 Telegram description	22
	6.2.3 Telegram example 1	22
	6.2.4 Telegram example 2	23
	6.2.5 Data types	23
7	Parameter set	24
7.1	General	24
7.2	Control commands	24
7.3	Status requests	24
7.4	Pressure value query	24
8	Operation	25

9	Disassembly	26
10	Maintenance	27
	10.1 Cleaning of components	27
	10.2 Calibrate the gauge	28
	10.3 Load factory settings	30
11	Shipping	31
12	Recycling and disposal	32
	12.1 General disposal information	32
	12.2 Dispose of gauges	32
13	Service solutions by Pfeiffer Vacuum	33
14	Accessories	35
	14.1 Accessory information	35
	14.2 Order accessories	35
15	Technical data and dimensions	36
	15.1 General	36
	15.2 Technical data	36
	15.3 Dimensions	38
	Declaration of conformity	39



List of tables

Tbl. 1:	Applicable documents	7
Tbl. 2:	Variants	7
Tbl. 3:	Abbreviations used	9
Tbl. 4:	Features of the RS-485 interface	21
Tbl. 5:	Explanation and meaning of the parameters	24
Tbl. 6:	Parameter set Status requests	24
Tbl. 7:	Parameter set Pressure value query	24
Tbl. 8:	"device status" LED	25
Tbl. 9:	Deviation of output signal between vertical upright and horizontal mounting orientation	28
Tbl. 10:	Recommended final pressure for zero point calibration	28
Tbl. 11:	Accessories	35
Tbl. 12:	Conversion table: Pressure units	36
Tbl. 13:	Conversion table: Units for gas throughput	36
Tbl. 14:	Measured and pressure values	37
Tbl. 15:	Electrical data	37
Tbl. 16:	RS-485 interface	37
Tbl. 17:	Internal volume and weight	38
Tbl. 18:	Ambient conditions	38
Tbl. 19:	Temperatures	38
Tbl. 20:	Substances in contact with the media	38



List of figures

Fig. 1:	Button and LED	16
Fig. 2:	Establish vacuum connection	19
Fig. 3:	Connection diagram	20
Fig. 4:	Terminal assignment of RS-485 connecting socket	20
Fig. 5:	Cross-link via connection RS-485 using connection cables and accessories	21
Fig. 6:	Zero point calibration with "zero" button	29
Fig. 7:	Use the "zero" button to load the factory settings	30
Fig. 8:	Dimensions	38



1 About this manual



IMPORTANT

Read carefully before use.

Keep the manual for future consultation.

1.1 Validity

This document describes the function of the products listed in the following and provides the most important information for safe use. The description is written in accordance with the valid directives. The information in this document refers to the current development status of the products. The document retains its validity assuming that the customer does not make any changes to the product.

1.1.1 Applicable documents

Designation	Document
Declaration of conformity	(Component of these instructions)

Tbl. 1: Applicable documents

1.1.2 Variants

This document applies to products with the following part numbers:

Part number	Type	Connection	Measuring range min/max.
PT R50 060	CCT 361	1/2" tube	0.1 hPa /1000 hPa
PT R50 130		DN 16 ISO-KF	
PT R50 320		DN 16 CF-R	
PT R50 430		8 VCR	
PT R51 060	CCT 362	1/2" tube	1 × 10 ⁻² hPa/100 hPa
PT R51 130		DN 16 ISO-KF	
PT R51 320		DN 16 CF-R	
PT R51 430		8 VCR	
PT R52 060	CCT 363	1/2" tube	1 × 10 ⁻³ hPa/10 hPa
PT R52 130		DN 16 ISO-KF	
PT R52 320		DN 16 CF-R	
PT R52 430		8 VCR	
PT R53 060	CCT 364	1/2" tube	1 × 10 ⁻⁴ hPa/1 hPa
PT R53 130		DN 16 ISO-KF	
PT R53 320		DN 16 CF-R	
PT R53 430		8 VCR	
PT R54 060	CCT 365	1/2" tube	1 × 10 ⁻⁵ hPa/0.1 hPa
PT R54 130		DN 16 ISO-KF	
PT R54 320		DN 16 CF-R	
PT R54 430		8 VCR	

Tbl. 2: Variants

You can find the part number on the rating plate of the product.

Pfeiffer Vacuum reserves the right to make technical changes without prior notification.

Information that relates to only one of the products is indicated accordingly.

The figures in this document are not to scale.

The figures show the product with a DN 16 ISO-KF vacuum connection, however, they also apply to the other vacuum connections where applicable.



Dimensions are provided in mm, unless specified otherwise.

1.2 Target group

These operating instructions are aimed at all persons performing the following activities on the product:

- Transportation
- Setup (Installation)
- Usage and operation
- Decommissioning
- Maintenance and cleaning
- Storage or disposal

The work described in this document is only permitted to be performed by persons with the appropriate technical qualifications (expert personnel) or who have received the relevant training from Pfeiffer Vacuum.

1.3 Conventions

1.3.1 Instructions in the text

Usage instructions in the document follow a general structure that is complete in itself. The required action is indicated by an individual step or multi-part action steps.

Individual action step

A horizontal, solid triangle indicates the only step in an action.

- ▶ This is an individual action step.

Sequence of multi-part action steps

The numerical list indicates an action with multiple necessary steps.

1. Step 1
2. Step 2
3. ...

1.3.2 Pictographs

The pictographs used in the document indicate useful information.



Note



Tip



Wear laboratory gloves



Perform a visual inspection

1.3.3 Stickers on the product

This section describes all the stickers on the product along with their meanings.

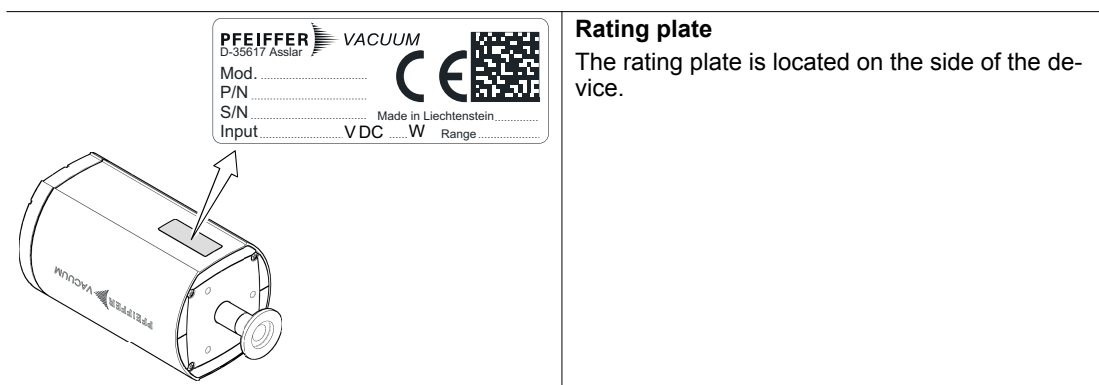

**Rating plate**

The rating plate is located on the side of the device.

1.3.4 Abbreviations

Abbreviation	Explanation
ATM	Atmosphere
DCU	Display and control unit by Pfeiffer Vacuum for DigiLine gauges
FS	Measuring range max. (full scale)
HU	Height unit of a 19" rack
HV	High vacuum
MSL	Mean sea level
[P:xxx]	Electronic drive unit control parameters. Printed in bold as a three-digit number in square brackets. Frequently displayed in conjunction with a short description. Example: [P:312] software version
p	Pressure
RS-485	Standard for a physical interface for asynchronous serial data transmission (recommended standard)
SPI	Standard for a synchronous serial data bus (serial peripheral interface)
TPS	Voltage supply (turbo power supply)

Tbl. 3: Abbreviations used

1.4 Trademark proof

- Binder® is a registered trademark of Franz Binder GmbH + Co. Elektrische Bauelemente KG.
- VCR® is a registered trademark of Swagelok Company.
- Vacon 70 is a trade name of Vacuumschmelze GmbH & Co. KG.

2 Safety

2.1 General safety information

The following 4 risk levels and 1 information level are taken into account in this document.

⚠ DANGER

Immediately pending danger
Indicates an immediately pending danger that will result in death or serious injury if not observed.

- ▶ Instructions to avoid the danger situation

⚠ WARNING

Potential pending danger
Indicates a pending danger that could result in death or serious injury if not observed.

- ▶ Instructions to avoid the danger situation

⚠ CAUTION

Potential pending danger
Indicates a pending danger that could result in minor injuries if not observed.

- ▶ Instructions to avoid the danger situation

NOTICE

Danger of damage to property
Is used to highlight actions that are not associated with personal injury.

- ▶ Instructions to avoid damage to property

i Notes, tips or examples indicate important information about the product or about this document.

2.2 Safety instructions

i **Safety instructions according to product's life stages**
All safety instructions in this document are based on the results of a risk assessment. Pfeiffer Vacuum has taken into account all the relevant life stages of the product.

Risks during installation

⚠ DANGER

Danger to life due to dangerous contact voltage
Voltages above 30 V (AC) or 60 V (DC) are considered dangerous in accordance with EN 61010. If you come into contact with dangerous contact voltage, this can result in injury through electric shocks or even death.

- ▶ Only connect the product to devices which meet the following criteria:
 - Requirements of the earthed protective extra-low voltage (PELV)
 - Limited power source (LPS) Class 2
- ▶ Secure the line to the product.
 - Pfeiffer Vacuum measuring and control equipment complies with this requirement.



⚠ DANGER**Risk to life due to electric shock**

An improperly earthed product is potentially fatal in the event of a fault.

- ▶ Connect the product galvanically with the earthed vacuum chamber.
- ▶ Ensure that the connection complies with the requirements of a protective bonding according to EN 61010.
- ▶ Use electrically conductive centering rings and circlips for KF connections.
- ▶ In case of a 1/2" tube connector, take appropriate action to meet the requirements.

⚠ DANGER**Danger to life from electric shock**

When establishing the voltages that exceed the specified safety extra-low voltage (according to IEC 60449 and VDE 0100), the insulating measures will be destroyed. There is a danger to life from electric shock at the communication interfaces.

- ▶ Connect only suitable devices to the bus system.

Risks during operation**⚠ WARNING****Risk of injury resulting from overpressure in the vacuum system**

Opening tensioning pieces with an overpressure > **1000 hPa** in the vacuum system can lead to injuries as a result of flying parts, and escaping process medium could prove harmful to health.

Elastomer seals in KF connections (e.g. O-rings) are not resistant to pressures > **2500 hPa**. This could prove harmful to health due to escaping process medium.

- ▶ Do not open any tensioning pieces when overpressure is prevalent in the vacuum system.
- ▶ Use suitable tensioning pieces for overpressure.
- ▶ Use tensioning pieces which can only be opened and closed using a tool (e.g. tightening strap-circlip).
- ▶ Use sealing rings with an outer centering ring.

Risks during maintenance**⚠ DANGER****Electric shocks due to moisture penetrating into the device**

Moisture that has penetrated into the device results in personal injury through electric shocks.

- ▶ Only operate the device in a dry environment.
- ▶ Operate the device away from fluids and humidity sources.
- ▶ Do not switch on the device if fluid has penetrated into it, instead contact Pfeiffer Vacuum Service.
- ▶ Always disconnect the current supply before cleaning the device.

⚠ WARNING**Health hazard through poisoning from toxic contaminated components or devices**

Toxic process media result in contamination of devices or parts of them. During maintenance work, there is a risk to health from contact with these poisonous substances. Illegal disposal of toxic substances causes environmental damage.

- ▶ Take suitable safety precautions and prevent health hazards or environmental pollution by toxic process media.
- ▶ Decontaminate affected parts before carrying out maintenance work.
- ▶ Wear protective equipment.

⚠ WARNING

Health hazards due to cleaning agent

The cleaning agent being used causes health hazards which could include, for example, poisoning, allergies, skin irritations, chemical burns or damage to the airways.

- ▶ When handling cleaning agents, observe the applicable regulations.
- ▶ Adhere to safety measures regarding handling and disposal of cleaning agents.
- ▶ Be aware of potential reactions with product materials.

Risks when shipping

⚠ WARNING

Risk of poisoning from contaminated products

Where products that contain harmful substances are shipped for maintenance or repair purposes, the health and safety of service personnel is at risk.

- ▶ Comply with the instructions for safe distribution.

Risks during disposal

⚠ WARNING

Health hazard through poisoning from toxic contaminated components or devices

Toxic process media result in contamination of devices or parts of them. During maintenance work, there is a risk to health from contact with these poisonous substances. Illegal disposal of toxic substances causes environmental damage.

- ▶ Take suitable safety precautions and prevent health hazards or environmental pollution by toxic process media.
- ▶ Decontaminate affected parts before carrying out maintenance work.
- ▶ Wear protective equipment.

2.3 Safety precautions

The product is designed according to the latest technology and recognized safety engineering rules. Nevertheless, improper use can result in danger to operator all third party life and limb, and product damage and additional property damage.

i

Duty to provide information on potential dangers

The product holder or user is obliged to make all operating personnel aware of dangers posed by this product.

Every person who is involved in the installation, operation or maintenance of the product must read, understand and adhere to the safety-related parts of this document.

i

Infringement of conformity due to modifications to the product

The Declaration of Conformity from the manufacturer is no longer valid if the operator changes the original product or installs additional equipment.

- Following the installation into a system, the operator is required to check and re-evaluate the conformity of the overall system in the context of the relevant European Directives, before commissioning that system.

General safety precautions when handling the product

- ▶ Observe all applicable safety and accident prevention regulations.
- ▶ Check that all safety measures are observed at regular intervals.
- ▶ Pass on safety instructions to all other users.
- ▶ Do not expose body parts to the vacuum.
- ▶ Always ensure a secure connection to the earthed conductor (PE).
- ▶ Never disconnect plug connections during operation.
- ▶ Observe the above shutdown procedures.
- ▶ Keep lines and cables away from hot surfaces (> 70 °C).



- ▶ Do not carry out your own conversions or modifications on the device.
- ▶ Observe the unit protection degree prior to installation or operation in other environments.
- ▶ Provide suitable touch protection, if the surface temperature exceeds 70 °C.
- ▶ Inform yourself about any contamination before starting work.

2.4 Proper use

The gauge is used for vacuum measurement of gases within its defined measuring range.

Use the product according to its intended purpose

- ▶ Operate the gauge with a Pfeiffer Vacuum DigiLine display and control unit or with an evaluation unit provided by the customer.
- ▶ Install, operate and maintain the gauge exclusively as prescribed in these operating instructions.
- ▶ Observe the application limits prescribed in the technical data.
- ▶ Observe the technical data.

2.5 Foreseeable improper use

Improper use of the product invalidates all warranty and liability claims. Any use that is counter to the purpose of the product, whether intentional or unintentional, is regarded as misuse, in particular:

- Use outside the mechanical and electrical application limits
- Use with corrosive or explosive media, if this is not explicitly permitted
- Use for the measurement of highly flammable or combustible gases mixed with an oxidizing agent (e.g. atmospheric oxygen) within the explosion limits
- Use outdoors
- Use after technical changes (on the inside or the outside of the product)
- Use with replacement or accessory parts that are unsuitable or are not approved

2.6 Responsibilities and warranty

Pfeiffer Vacuum shall assume no responsibilities and warranty if the operating company or a third party:

- disregards this document
- does not use the product for its intended purpose
- carries out any modifications to the product (conversions, changes, etc.) that are not listed in the corresponding product documentation
- operates the product with accessories that are not listed in the corresponding product documentation

The operator is responsible for the process media used.

2.7 Owner requirements

Safety-conscious working

1. Only operate the product in a technically flawless state.
2. Operate the product in line with its intended purpose, safety and hazard-conscious and only in compliance with these operating instructions.
3. Fulfill the following instructions and monitor the observation of the following instructions:
 - Proper use
 - Generally applicable safety instructions and accident prevention regulations
 - International, national and locally applicable standards and guidelines
 - Additional product-related guidelines and regulations
4. Only use original parts or parts approved by Pfeiffer Vacuum.
5. Keep the operating instructions available at the place of installation.
6. Ensure personnel qualification.

2.8 Personnel qualification

The work described in this document may only be carried out by persons who have appropriate professional qualifications and the necessary experience or who have completed the necessary training as provided by Pfeiffer Vacuum.

Training people

1. Train the technical personnel on the product.
2. Only let personnel to be trained work with and on the product when under the supervision of trained personnel.
3. Only allow trained technical personnel to work with the product.
4. Before starting work, make sure that the commissioned personnel have read and understood these operating instructions and all applicable documents, in particular the safety, maintenance and repair information.

2.8.1 Ensuring personnel qualification

Specialist for mechanical work

Only a trained specialist may carry out mechanical work. Within the meaning of this document, specialists are people responsible for construction, mechanical installation, troubleshooting and maintenance of the product, and who have the following qualifications:

- Qualification in the mechanical field in accordance with nationally applicable regulations
- Knowledge of this documentation

Specialist for electrotechnical work

Only a trained electrician may carry out electrical engineering work. Within the meaning of this document, electricians are people responsible for electrical installation, commissioning, troubleshooting, and maintenance of the product, and who have the following qualifications:

- Qualification in the electrical engineering field in accordance with nationally applicable regulations
- Knowledge of this documentation

In addition, these individuals must be familiar with applicable safety regulations and laws, as well as the other standards, guidelines, and laws referred to in this documentation. The above individuals must have an explicitly granted operational authorization to commission, program, configure, mark, and earth devices, systems, and circuits in accordance with safety technology standards.

Trained individuals

Only adequately trained individuals may carry out all works in other transport, storage, operation and disposal fields. Such training must ensure that individuals are capable of carrying out the required activities and work steps safely and properly.

2.8.2 Personnel qualification for maintenance and repair



Advanced training courses

Pfeiffer Vacuum offers advanced training courses to maintenance levels 2 and 3.

Adequately trained individuals are:

- **Maintenance level 1**
 - Customer (trained specialist)
- **Maintenance level 2**
 - Customer with technical education
 - Pfeiffer Vacuum service technician
- **Maintenance level 3**
 - Customer with Pfeiffer Vacuum service training
 - Pfeiffer Vacuum service technician

2.8.3 Advanced training with Pfeiffer Vacuum

For optimal and trouble-free use of this product, Pfeiffer Vacuum offers a comprehensive range of courses and technical trainings.

For more information, please contact [Pfeiffer Vacuum technical training](#).



2.9 Operator requirements

Observing relevant documents and data

1. Read, observe and follow this operating instruction and the work instructions prepared by the operating company, in particular the safety and warning instructions.
2. Install, operate and maintain the product only in accordance with these operating instructions.
3. Carry out all work only on the basis of the complete operating instructions and applicable documents.
4. Comply with the application limits.
5. Observe the technical data.
6. Please contact the Pfeiffer Vacuum Service Center if your questions on operation or maintenance of the product are not answered by these operating instructions.
 - You can find information in the [Pfeiffer Vacuum service area](#).

3 Product description

3.1 Function

The gauge has a capacitive measuring element with a ceramic diaphragm. The pressure deflects the ceramic diaphragm. The diaphragm capacitance changes. The electronics convert the capacitance change to a digital output signal. The digital pressure value output is independent of the gas type to be measured.

3.2 Button and status display

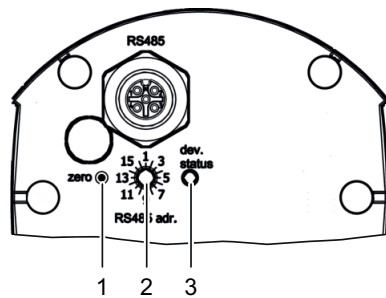

Fig. 1: Button and LED

- | | |
|--|--|
| <ol style="list-style-type: none"> 1 "zero" button for zero point calibration 2 RS-485 address selector switch | <ol style="list-style-type: none"> 3 "device status" LED (gauge status) |
|--|--|

3.3 Identifying the product

You will need all the data from the rating plate to safely identify the product when communicating with Pfeiffer Vacuum.

1. Read the data on the product rating plate.
2. Record this data.
3. Always have all rating plate specifications to hand.

3.4 Scope of delivery

The scope of delivery includes the following parts:

- Gauge (in clean room packaging)
- Stylus (Ø 1.1 mm)
- Calibration certificate
- Operating instructions

Unpacking the product and checking completeness of the shipment

1. Unpack the product.
2. Remove the transport fasteners, transport protection etc.
3. Store the transport fasteners, transport protection etc. in a safe place.
4. Check that the shipment is complete.
5. Ensure that no parts are damaged.



4 Transport and storage

4.1 Transporting the product

NOTICE

Damage caused by incorrect transportation

Transportation in unsuitable packaging, or failure to install all transport locks, can damage the product.

- ▶ Comply with the instructions for safe transportation.



Packing

We recommend keeping the transport packaging and original protective cover.

General information regarding safe transport

- ▶ Observe the weight specified on the transport packaging.
- ▶ Where possible, always transport or ship the product in the original transport packaging.
- ▶ Always use dense and impact-proof transport packaging for the product.
- ▶ Remove the existing protective cover and transport protections only immediately prior to installation.
- ▶ Reattach transport locks and transport protections prior to each transport.

4.2 Storing the product

NOTICE

Damage caused by improper storage

Improper storage will lead to damage to the product.

Static charging, moisture, etc. lead to defects on the electronic components.

- ▶ Comply with the instructions for safe storage.



Packing

We recommend storing the product in its original packaging.

General information for safe storage

- ▶ Store the product in a cool, dry, dust-free place, where it is protected against impacts and mechanical vibration.
- ▶ Always use dense and impact-proof packaging for the product.
- ▶ Where possible, store the product in its original packaging.
- ▶ Store electronic components in antistatic packaging.
- ▶ Maintain the permissible storage temperature.
- ▶ Avoid extreme fluctuations of the ambient temperature.
- ▶ Avoid high air humidity.
- ▶ Seal connections with the original protective caps.
- ▶ Protect the product with the original transport protection (where available).



5 Installation

5.1 Establish vacuum connection

⚠ DANGER

Risk to life due to electric shock

An improperly earthed product is potentially fatal in the event of a fault.

- ▶ Connect the product galvanically with the earthed vacuum chamber.
- ▶ Ensure that the connection complies with the requirements of a protective bonding according to EN 61010.
- ▶ Use electrically conductive centering rings and circlips for KF connections.
- ▶ In case of a 1/2" tube connector, take appropriate action to meet the requirements.

⚠ WARNING

Risk of injury resulting from overpressure in the vacuum system

Opening tensioning pieces with an overpressure > **1000 hPa** in the vacuum system can lead to injuries as a result of flying parts, and escaping process medium could prove harmful to health.

Elastomer seals in KF connections (e.g. O-rings) are not resistant to pressures > **2500 hPa**. This could prove harmful to health due to escaping process medium.

- ▶ Do not open any tensioning pieces when overpressure is prevalent in the vacuum system.
- ▶ Use suitable tensioning pieces for overpressure.
- ▶ Use tensioning pieces which can only be opened and closed using a tool (e.g. tightening strap-circlip).
- ▶ Use sealing rings with an outer centering ring.

NOTICE

Impairment from contamination and damage

Touching the devices or components with bare hands increases the desorption rate and leads to incorrect measurements. Dirt (e.g. dust, fingerprints, etc.) and damage impair the function.

- ▶ When working on high or ultra high vacuum systems, always wear clean, lint-free and powder-free laboratory gloves.
- ▶ Only use clean tools.
- ▶ Make sure that the connection flanges are free of grease.
- ▶ Remove protective caps and protective covers from flanges and connections only when necessary.
- ▶ Carry out all work in a well lit area.

NOTICE

Damage caused by vibrations

Vibrations and strikes destroy the ceramic sensor, which is sensitive to shocks.

- ▶ Treat the gauge carefully.
- ▶ Avoid vibrations and strikes.
- ▶ Do not drop the gauge.

Prerequisites

- Appropriate ambient conditions
- Operating temperature within permissible range
- Adequate room available for electrical connection (e.g. permissible bending radii for cables)



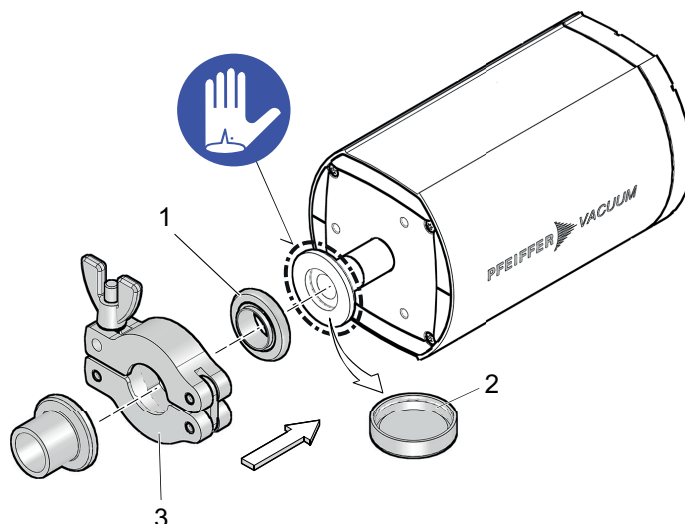

Fig. 2: Establish vacuum connection

- | | |
|----------------------------|--------------------|
| 1 Seal with centering ring | 3 Tensioning piece |
| 2 Protective cap | |

Procedure

1. If possible, make sure that the gauge is not exposed to any vibrations during operation, as vibrations will lead to deviations in the measured values.
2. Recommendation: Install the gauge in a horizontal to upright mounting orientation (flange facing downwards).
 - This prevents condensate and particles from accumulating in the measurement chamber.
3. Ensure that the button of the gauge can be easily accessed with the stylus once fitted.
4. Recommendation: Fit a seal with centering ring and filter for applications with pollution and to protect the measurement system against contamination.
5. Remove the protective cap and store in a safe place.
6. Assemble the gauge with vacuum components from the [Pfeiffer Vacuum Components Shop](#) on the vacuum system.

5.2 Establish "RS-485" connection

⚠ DANGER

Danger to life due to dangerous contact voltage

Voltages above 30 V (AC) or 60 V (DC) are considered dangerous in accordance with EN 61010. If you come into contact with dangerous contact voltage, this can result in injury through electric shocks or even death.

- ▶ Only connect the product to devices which meet the following criteria:
 - Requirements of the earthed protective extra-low voltage (PELV)
 - Limited power source (LPS) Class 2
- ▶ Secure the line to the product.
 - Pfeiffer Vacuum measuring and control equipment complies with this requirement.

NOTICE

Property damage due to ground contact of electronics

Disconnecting or connecting the "RS-485" plug-and-socket connection with the voltage supply switched leads to the destruction of electronic components.

- ▶ Always interrupt the voltage supply before you plug in or unplug the "RS-485" power supply plug.
- ▶ Switch off the power supply pack.
- ▶ After switching off the power supply pack, wait until the residual load has dispersed completely before disconnecting or connecting the plug-and-socket connection.



The connector designated "RS-485" is intended for connecting an external power supply pack (TPS) or PC. The gauge is protected against polarity reversal of the supply voltage.

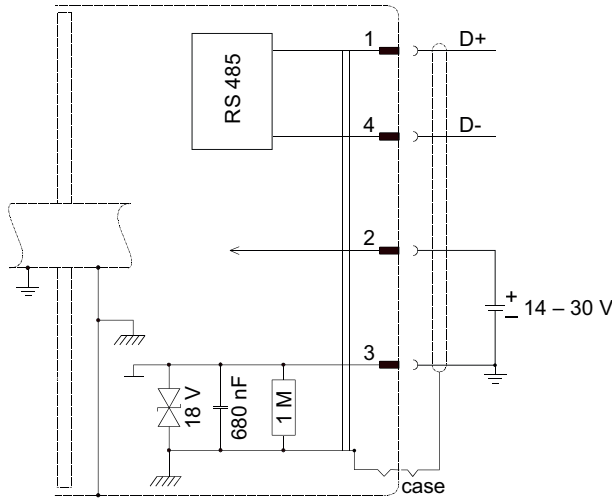

Fig. 3: Connection diagram

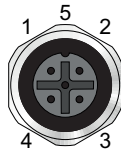

Fig. 4: Terminal assignment of RS-485 connecting socket

- | | |
|-------------------|-----------------|
| 1 RS-485 D+ | 4 RS-485 D- |
| 2 +14 to +30 V DC | 5 not connected |
| 3 GND | |

Manufacture measurement cable

For additional information on the measurement cable see the technical data.

1. Observe the following steps to ensure optimum signal quality, whereby ground loops, differences in potential or EMC will influence the measuring signal.
2. Use a cable with braided shield.
3. Connect the cable shielding to the ground via the connector housing on one side only.
4. Leave the other shielding end open.
5. Connect the supply earth directly with the protective earth on the power supply pack.
6. Ensure that the potential difference for surge protection between the supply earth and the housing is ≤ 18 V.

Connect external power supply pack or PC

- ▶ Use the connection cable from the power supply pack scope of delivery or from the [DigilLine accessories program](#).
- ▶ In each case, connect only one external power supply pack to the RS-485 interface.
- ▶ If needed, connect a PC via the USB/RS-485 converter.



6 Interfaces

6.1 Interface RS-485

⚠ DANGER

Danger to life from electric shock

When establishing the voltages that exceed the specified safety extra-low voltage (according to IEC 60449 and VDE 0100), the insulating measures will be destroyed. There is a danger to life from electric shock at the communication interfaces.

- ▶ Connect only suitable devices to the bus system.

The gauge communicates via the "RS-485" interface. The gauge has the addresses 1 through 16.

Designation	Value
Serial interface	RS-485
Baud rate	9600 Baud
Data word length	8 bit
Parity	none (no parity)
Start bits	1
Stop bits	1

Tbl. 4: Features of the RS-485 interface

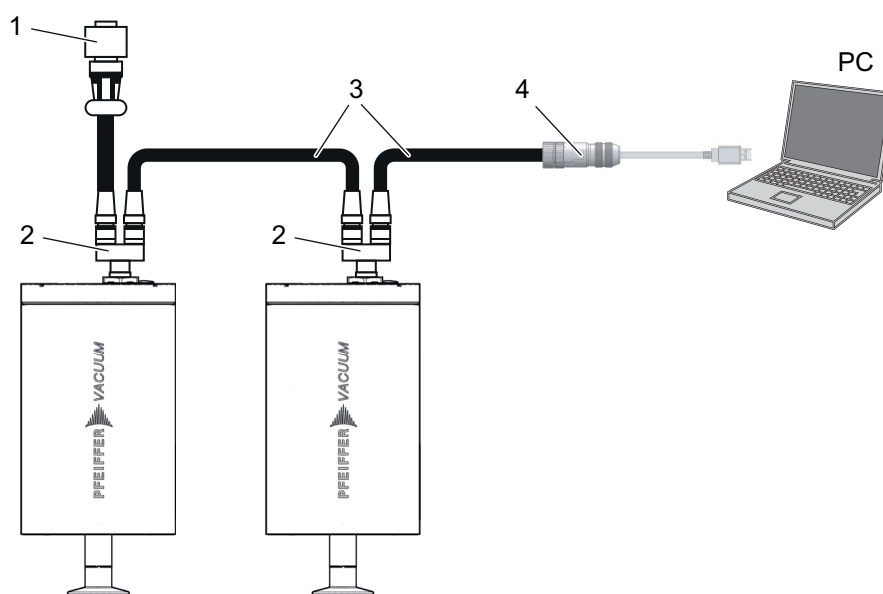

Fig. 5: Cross-link via connection RS-485 using connection cables and accessories

- | | |
|--------------------------|------------------------|
| 1 Supply cable DigiLine | 3 Interface cable M12 |
| 2 Y-connector for RS-485 | 4 USB/RS-485 converter |

Required tool

- Slot screwdriver

Set RS-485 address



1. Set the RS-485 address with the RS-485 address selector switch on the gauge.

Cross-linked via the RS-485 connection

1. Install the devices according to the specification for RS-485 interfaces.
2. Make sure that all devices connected to the bus have different RS-485 device addresses.
3. Connect all devices with RS-485 D+ and RS-485 D- to the bus.

6.2 Pfeiffer Vacuum protocol for RS-485 interface

6.2.1 Telegram frame

The telegram frame of the Pfeiffer Vacuum protocol contains only ASCII code characters [32; 127], the exception being the end character of the telegram C_R . Basically, a master  (e.g. a PC) sends a telegram, which a slave  (e.g. electronic drive unit or gauge) responds to.

a2	a1	a0	*	0	n2	n1	n0	l1	l0	dn	...	d0	c2	c1	c0	C_R
a2 – a0		Unit address for slave 														
		<ul style="list-style-type: none"> • Individual address of the unit ["001";"255"] • Group address "9xx" for all identical units (no response) • Global address "000" for all units on the bus (no response) 														
*		Action according to telegram description														
n2 – n0		Pfeiffer Vacuum parameter numbers														
l1 – l0		Data length dn to d0														
dn – d0		Data in the respective data type (see chapter "Data types", page 23).														
c2 – c0		Checksum (sum of ASCII values of cells a2 to d0) modulo 256														
C_R		carriage return (ASCII 13)														

6.2.2 Telegram description

Data query  -->  ?

a2	a1	a0	0	0	n2	n1	n0	0	2	=	?	c2	c1	c0	C_R
----	----	----	---	---	----	----	----	---	---	---	---	----	----	----	-------

Control command  -->  !

a2	a1	a0	1	0	n2	n1	n0	l1	l0	dn	...	d0	c2	c1	c0	C_R
----	----	----	---	---	----	----	----	----	----	----	-----	----	----	----	----	-------

Data response / Control command understood  --> 

a2	a1	a0	1	0	n2	n1	n0	l1	l0	dn	...	d0	c2	c1	c0	C_R
----	----	----	---	---	----	----	----	----	----	----	-----	----	----	----	----	-------

Error message  --> 



a2	a1	a0	1	0	n2	n1	n0	0	6	N	O	_	D	E	F	c2	c1	c0	C_R
										_	R	A	N	G	E				
										_	L	O	G	I	C				

NO_DEF Parameter number n2–n0 no longer exists
 _RANGE Data dn–d0 outside the permissible range
 _LOGIC Logical access error

6.2.3 Telegram example 1



Pressure value query

Current measured pressure (parameter [P:740], slave device address: "001")

 -->  ?	0	0	1	0	0	7	4	0	0	2	=	?	1	0	6	C_R
ASCII	48	48	49	48	48	55	52	48	48	50	61	63	49	48	54	13

Data response: measured pressure $1 \times 10^{+3}$ hPa as exponent 1E+3

Current measured pressure (parameter [P:740], slave device address: "001")

 --> 	0	0	1	1	0	7	4	0	0	6	1	0	0	0	2	3	0	2	5	C_R
ASCII	48	48	49	49	48	55	52	48	48	54	49	48	48	48	50	51	48	50	53	13



6.2.4 Telegram example 2

Incorrect command

Incorrect command (parameter [P:888], slave device address: "005")

☐ --> ☐!	0	0	5	1	0	8	8	8	0	3	1	3	0	c2	c1	c0	c _R
ASCII	48	48	53	49	48	56	56	56	48	51	49	51	48				13

Unknown command

Incorrect command (parameter [P:888], slave device address: "005")

☐ --> ☐	0	0	5	1	0	8	8	8	0	6	N	O	_	D	E	F	c2	c1	c0	c _R
ASCII	48	48	53	49	48	56	56	56	48	54	78	79	95	68	69	70				13

6.2.5 Data types

No.	Data type	Description	Length I1 – I0	Example
0	boolean_old	Logical value (false/true)	06	000000 corresponds with false 111111 corresponds with true
1	u_integer	Positive whole number	06	000000 to 999999
2	u_real	Positive fixed point number	06	001571 corresponds with 15.71
3	u_expo	Positive exponential number	06	1.2E-2 corresponds with $1,2 \cdot 10^{-2}$ 005E8 corresponds with $5 \cdot 10^8$
4	string	Any character string with 6 characters. ASCII codes between 32 and 127	06	TC_110, TM_700
6	boolean_new	Logical value (false/true)	01	0 corresponds with false 1 corresponds with true
7	u_short_int	Positive whole number	03	000 to 999
10	u_expo_new	Positive exponential number. The last of both digits are the exponent with a deduction of 20.	06	100023 corresponds with $1,0 \cdot 10^3$ 100000 corresponds with $1,0 \cdot 10^{-20}$
11	string16	Any character string with 16 characters. ASCII codes between 32 and 127	16	this-is-an-example
12	string8	Any character string with 8 characters. ASCII codes between 32 and 127	08	Example



7 Parameter set

7.1 General

All functionally-relevant variables of the gauge are stored as parameters. Each parameter has a three-digit number and a description. Parameters can be used via Pfeiffer Vacuum display and control panels or via RS-485 with the Pfeiffer Vacuum protocol.

Factory settings

The gauge is pre-programmed ex factory. The gauge is ready for safe operation without additional configuration.

#	Three digit number of the parameter
Description	Brief description of the parameters
Functions	Function description of the parameters
Data type	Type of formatting of the parameter for the use with the Pfeiffer Vacuum protocol
Access type	R (read): Read access; W (write): Write access
Unit	Physical unit of the described variable
min. / max.	Permissible limit values for the entry of a value
default	Factory default pre-setting (partially pump-specific)
	The parameter can be saved persistently in the electronic drive unit

Tbl. 5: Explanation and meaning of the parameters

7.2 Control commands

The gauge does not have any control commands.

7.3 Status requests

#	Display	Description	Functions	Data type	Access type	Unit	min.	max.	de-fault	can be stored
303	Error code	Error code	000000 = No error Err001 = Sensor defective Err002 = Memory defective	4	R					
312	Fw version	Gauge firmware version		4	R					
349	ElecName	Device name		4	R					

Tbl. 6: Parameter set | Status requests

7.4 Pressure value query

#	Display	Designations	Functions	Data type	Access type	Unit	min.	max.	de-fault	can be stored
740	Pressure	Pressure value	Pressure value in format aaaabb aaaa = mantissa bb = exponent	10	R	hPa				

Tbl. 7: Parameter set | Pressure value query



8 Operation

Recommendations

- ▶ On initial operation, perform zero point calibration.
- ▶ Allow a start-up time of at least 15 minutes for general pressure measurements within the specifications.
- ▶ Allow a start-up time of at least 2 hours for precision measurements and zero point calibration.

LED	Meaning
Off	No power supply
Lights up green	Supply voltage OK, measuring mode
Flashes green	Wait for SPI communication with gauge
Lights up yellow	Other mode (e.g. Zero Adjust), measuring range exceeded/under-shot
Lights up red	Software or gauge error
Lit for 1 s green, yellow and red	LED test after commissioning or reset
Flashing red/green	Software update in progress

Tbl. 8: "device status" LED

Query current measured pressure

- ▶ Query current measured pressure via parameter **[P:740]**.



Read pressure value display

Pressure values are transferred in the "aaaabb" format. The "aaaa" string is the mantissa of an exponential function and "bb" the exponent with an offset of 20. "aaaa" lies in the range "1000" (for 1.000) to "9999" (for 9.999). The individual characters in the string are the numbers "0" (ASCII 48) to "9" (ASCII 57).

Depending on the gauge and its accuracy, the number of significant figures in the mantissa can vary.

- Example 1: "104223" is equivalent to $1.042 \times 10^{+3}$ hPa
- Example 2: "750015" is equivalent to 7.500×10^{-5} hPa



9 Disassembly

⚠ DANGER

Risk to life due to electric shock

An improperly earthed product is potentially fatal in the event of a fault.

- ▶ Connect the product galvanically with the earthed vacuum chamber.
- ▶ Ensure that the connection complies with the requirements of a protective bonding according to EN 61010.
- ▶ Use electrically conductive centering rings and circlips for KF connections.
- ▶ In case of a 1/2" tube connector, take appropriate action to meet the requirements.

⚠ WARNING

Health hazard through poisoning from toxic contaminated components or devices

Toxic process media result in contamination of devices or parts of them. During maintenance work, there is a risk to health from contact with these poisonous substances. Illegal disposal of toxic substances causes environmental damage.

- ▶ Take suitable safety precautions and prevent health hazards or environmental pollution by toxic process media.
- ▶ Decontaminate affected parts before carrying out maintenance work.
- ▶ Wear protective equipment.

⚠ WARNING

Risk of injury resulting from overpressure in the vacuum system

Opening tensioning pieces with an overpressure $> 1000 \text{ hPa}$ in the vacuum system can lead to injuries as a result of flying parts, and escaping process medium could prove harmful to health.

Elastomer seals in KF connections (e.g. O-rings) are not resistant to pressures $> 2500 \text{ hPa}$. This could prove harmful to health due to escaping process medium.

- ▶ Do not open any tensioning pieces when overpressure is prevalent in the vacuum system.
- ▶ Use suitable tensioning pieces for overpressure.
- ▶ Use tensioning pieces which can only be opened and closed using a tool (e.g. tightening strap-circlip).
- ▶ Use sealing rings with an outer centering ring.

NOTICE

Impairment from contamination and damage

Touching the devices or components with bare hands increases the desorption rate and leads to incorrect measurements. Dirt (e.g. dust, fingerprints, etc.) and damage impair the function.

- ▶ When working on high or ultra high vacuum systems, always wear clean, lint-free and powder-free laboratory gloves.
- ▶ Only use clean tools.
- ▶ Make sure that the connection flanges are free of grease.
- ▶ Remove protective caps and protective covers from flanges and connections only when necessary.
- ▶ Carry out all work in a well lit area.

Prerequisites

- Vacuum system vented to atmospheric pressure
- Supply voltage switched off

Disassembling the gauge

1. Disconnect the measurement cable from the gauge.
2. Disassemble the gauge from the vacuum system.
3. Fit the protective cap onto the connection flange.



10 Maintenance

WARNING

Health hazard through poisoning from toxic contaminated components or devices

Toxic process media result in contamination of devices or parts of them. During maintenance work, there is a risk to health from contact with these poisonous substances. Illegal disposal of toxic substances causes environmental damage.

- ▶ Take suitable safety precautions and prevent health hazards or environmental pollution by toxic process media.
- ▶ Decontaminate affected parts before carrying out maintenance work.
- ▶ Wear protective equipment.



Maintenance in the Pfeiffer Vacuum Service Center

Pfeiffer Vacuum offers a complete maintenance service for all products.

Pfeiffer Vacuum recommends: Contact your Pfeiffer Vacuum Service Center to arrange the maintenance of defective products and components.



Cleaning in the Pfeiffer Vacuum Service Center

Pfeiffer Vacuum recommends: Contact your nearest Pfeiffer Vacuum Service Center to arrange the cleaning of heavily-soiled products and components.



Loss of warranty claims

The following will result in the loss of the warranty:

- Damage to or removal of a closure seal
- Opening the device during the warranty period

Contact the Pfeiffer Vacuum Service Center in the event of process-related shorter maintenance intervals.



Warranty

Malfunctioning of the equipment as a direct result of contamination or wear, as well as wear parts, is not covered by the warranty.



First read through the sections completely

Read the section with the work instructions through completely first before you commence with work.

The gauge is maintenance-free in clean operating conditions. Long-term operation or contamination can lead to a zero point shift. A zero point shift necessitates recalibration.

10.1 Cleaning of components

DANGER

Electric shocks due to moisture penetrating into the device

Moisture that has penetrated into the device results in personal injury through electric shocks.

- ▶ Only operate the device in a dry environment.
- ▶ Operate the device away from fluids and humidity sources.
- ▶ Do not switch on the device if fluid has penetrated into it, instead contact Pfeiffer Vacuum Service.
- ▶ Always disconnect the current supply before cleaning the device.



⚠ WARNING

Health hazards due to cleaning agent

The cleaning agent being used causes health hazards which could include, for example, poisoning, allergies, skin irritations, chemical burns or damage to the airways.

- ▶ When handling cleaning agents, observe the applicable regulations.
- ▶ Adhere to safety measures regarding handling and disposal of cleaning agents.
- ▶ Be aware of potential reactions with product materials.

NOTICE

Damage caused by penetrating moisture

Penetrating moisture, e.g. through condensation or dripping water, damages the device.

- ▶ Protect the device against moisture penetrating.
- ▶ Only operate the device in a clean and dry environment.
- ▶ Operate the device away from fluids and humidity sources.
- ▶ Take special precautions if there is a risk of dripping water.
- ▶ Do not switch on the device if fluid has penetrated into it, instead contact the Pfeiffer Vacuum Service Center.

NOTICE

Damage caused by unsuitable cleaning agents

Unsuitable cleaning agents damage the product.

- ▶ Do not use solvents as they attack the surface.
- ▶ Do not use any aggressive or abrasive cleaning agents.

Required consumables

- Industrial alcohol
- Cloth (soft, lint-free)

External cleaning of the device

1. Always use a cloth soaked in industrial alcohol for external cleaning.
2. Allow the surfaces to dry thoroughly after cleaning.

10.2 Calibrate the gauge

Pfeiffer Vacuum calibrated the gauge ex factory in vertical upright position. The output signal is dependent upon the installation position.

FS	$\Delta p/90^\circ$ (horizontal)
1000 hPa	approx. 0.25 hPa
100 hPa	approx. 0.13 hPa
10 hPa	approx. 0.063 hPa
1 hPa	approx. 0.038 hPa
0.1 hPa	approx. 0.023 hPa

Tbl. 9: Deviation of output signal between vertical upright and horizontal mounting orientation

FS	Recommended final pressure
1000 hPa	$< 5 \times 10^{-2}$ hPa
100 hPa	$< 5 \times 10^{-3}$ hPa
10 hPa	$< 5 \times 10^{-4}$ hPa
1 hPa	$< 5 \times 10^{-5}$ hPa
0.1 hPa	$< 1 \times 10^{-5}$ hPa

Tbl. 10: Recommended final pressure for zero point calibration



Required tool

- Stylus (max. \varnothing 1.1 mm)

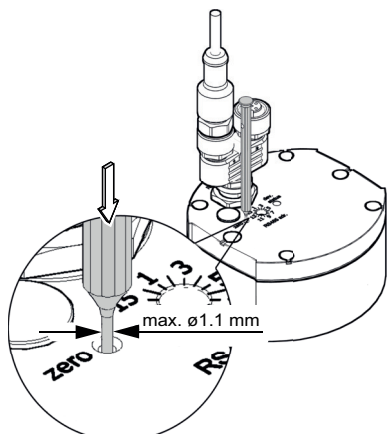

Fig. 6: Zero point calibration with "zero" button

Preparing for calibration

1. Ensure the same installation and ambient conditions as those applicable for normal use.
2. Check the filter for contamination as required.
3. Replace the filter if the filter is contaminated or damaged.
4. Put the gauge into operation.

**Zero point calibration in case of excessive final pressure**

Zero point calibration at an excessive final pressure ($> 25\%$ of FS) means that you will not reach zero. The "device status" LED flashes. First activate the factory settings, then repeat zero point calibration.

Perform zero point calibration

1. If possible, commission the gauge in the subsequent mounting orientation.
2. Evacuate the gauge to the recommended final pressure.
3. Operate the gauge for at least 2 hours until the measured value is stable.
4. Using a stylus, briefly press the "zero" button.
 - Zero point calibration occurs automatically.

The "device status" LED lights up yellow until the zero point calibration is complete (duration ≤ 8 s). The "device status" LED lights up yellow if the zero point calibration fails. Following zero point calibration, the gauge automatically returns to measuring mode. The "device status" LED lights up green.

You can use the ramp to:

- adjust the zero point in case of a known reference pressure that lies within the gauge's measuring range
- adjust a characteristic offset to compensate for an offset of the measurement system

**Offset $< 2\%$ of FS**

The offset should not be greater than 2% of the FS. In case of a larger positive offset, you will exceed the upper measuring range limit.

Perform zero point calibration with ramp function

1. If possible, commission the gauge in the subsequent mounting orientation.
2. Operate the gauge for at least 2 hours until the measured value is stable.
3. Using a stylus, press and hold down the "zero" button.
 - The "device status" LED starts to light up. After 5 s, the zero-adjust value changes continuously (ramp) from the current output value until you release the button or the setting limit (max. 25 % FS) is reached. The signal is output with a delay of approx. 1 s.
4. Release the "zero" button and hold it down again within 3 to 5 s to change direction (inverse ramp).
 - The LED "device status" briefly goes out and then lights up again.



5. Release the "zero" button and press it again within 3 s (approx. 1x per second) to perform fine adjustment of the zero-adjust value.
6. Do not press the "zero" button for longer than 5 s.
 - The gauge returns to measuring mode.

The "device status" LED lights up yellow if the gauge reaches the underrange status.

10.3 Load factory settings



Modified settings are lost

This function allows you to reset all parameters set/changed by the user to the default values (factory settings). All modified settings are lost on resetting to the factory settings. You cannot undo this function.

Required tool

- Stylus (max. \varnothing 1.1 mm)

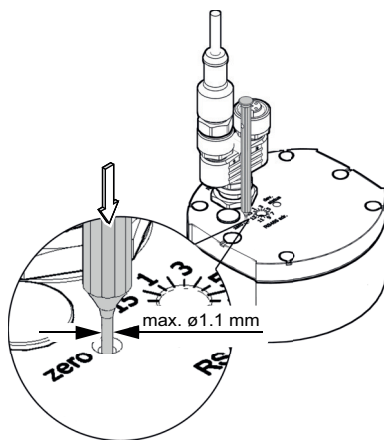

Fig. 7: Use the "zero" button to load the factory settings

Procedure

1. Decommission the gauge.
2. Commission the gauge and at same time hold down the "zero" button with a stylus for longer than 5 seconds.
 - The gauge loads the factory settings.



11 Shipping

WARNING

Risk of poisoning from contaminated products

Where products that contain harmful substances are shipped for maintenance or repair purposes, the health and safety of service personnel is at risk.

- ▶ Comply with the instructions for safe distribution.



Decontamination subject to charge

Pfeiffer Vacuum decontaminates products not clearly declared "Free of contamination" at your expense.

Instructions for safe shipping

- ▶ Do not ship microbiological, explosive or radioactively contaminated products.
- ▶ Observe the shipping guidelines for the participating countries and transport companies.
- ▶ Highlight any potential dangers on the outside of the packaging.
- ▶ Download the explanation for contamination at [Pfeiffer Vacuum Service](#).
- ▶ Always enclose a completed declaration of contamination.



12 Recycling and disposal

WARNING

Health hazard through poisoning from toxic contaminated components or devices

Toxic process media result in contamination of devices or parts of them. During maintenance work, there is a risk to health from contact with these poisonous substances. Illegal disposal of toxic substances causes environmental damage.

- ▶ Take suitable safety precautions and prevent health hazards or environmental pollution by toxic process media.
- ▶ Decontaminate affected parts before carrying out maintenance work.
- ▶ Wear protective equipment.



Environmental protection

You **must** dispose of the product and its components in accordance with all applicable regulations for protecting people, the environment and nature.

- Help to reduce the wastage of natural resources.
- Prevent contamination.



Environmental protection

The product and its components **must be disposed of in accordance with the applicable regulations relating to environmental protection and human health**, with a view to reducing natural resource wastage and preventing pollution.

12.1 General disposal information

Pfeiffer Vacuum products contain materials that you must recycle.

- ▶ Dispose of our products according to the following:
 - Iron
 - Aluminium
 - Copper
 - Synthetic
 - Electronic components
 - Oil and fat, solvent-free
- ▶ Observe the special precautionary measures when disposing of:
 - Fluoroelastomers (FKM)
 - Potentially contaminated components that come into contact with media

12.2 Dispose of gauges

Pfeiffer Vacuum gauges contain materials that you must recycle.

1. Dismantle the electronic unit.
2. Decontaminate the components that come into contact with process gases.
3. Separate the components into recyclable materials.
4. Recycle the non-contaminated components.
5. Dispose of the product or components in a safe manner according to locally applicable regulations.



13 Service solutions by Pfeiffer Vacuum

We offer first-class service

High vacuum component service life, in combination with low downtime, are clear expectations that you place on us. We meet your needs with efficient products and outstanding service.

We are always focused on perfecting our core competence – servicing of vacuum components. Once you have purchased a product from Pfeiffer Vacuum, our service is far from over. This is often exactly where service begins. Obviously, in proven Pfeiffer Vacuum quality.

Our professional sales and service employees are available to provide you with reliable assistance, worldwide. Pfeiffer Vacuum offers an entire range of services, from [original replacement parts](#) to [service contracts](#).

Make use of Pfeiffer Vacuum service

Whether preventive, on-site service carried out by our field service, fast replacement with mint condition replacement products, or repair carried out in a [Service Center](#) near you – you have various options for maintaining your equipment availability. You can find more detailed information and addresses on our homepage, in the [Pfeiffer Vacuum Service](#) section.

You can obtain advice on the optimal solution for you, from your [Pfeiffer Vacuum representative](#).

For fast and smooth service process handling, we recommend the following:

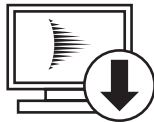

1. Download the up-to-date form templates.
 - [Explanations of service requests](#)
 - [Service requests](#)
 - [Contamination declaration](#)



- a) Remove and store all accessories (all external parts, such as valves, protective screens, etc.).
 - b) If necessary, drain operating fluid/lubricant.
 - c) If necessary, drain coolant.
2. Complete the service request and contamination declaration.



3. Send the forms by email, fax, or post to your local [Service Center](#).



4. You will receive an acknowledgment from Pfeiffer Vacuum.

PFEIFFER VACUUM

Submission of contaminated products

No microbiological, explosive, or radiologically contaminated products will be accepted. Where products are contaminated, or the contamination declaration is missing, Pfeiffer Vacuum will contact you before starting service work. Depending on the product and degree of pollution, **additional decontamination costs** may be incurred.



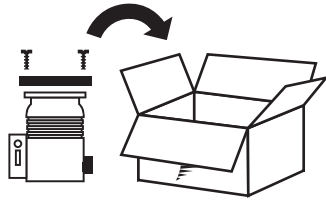

5. Prepare the product for transport in accordance with the provisions in the contamination declaration.
 - a) Neutralize the product with nitrogen or dry air.
 - b) Seal all openings with blind flanges, so that they are airtight.
 - c) Shrink-wrap the product in suitable protective foil.
 - d) Package the product in suitable, stable transport containers only.
 - e) Maintain applicable transport conditions.

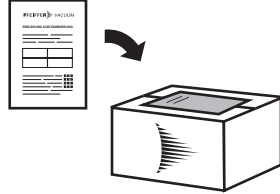

6. Attach the contamination declaration to the **outside** of the packaging.

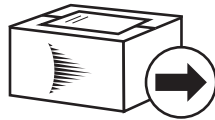

7. Now send your product to your local Service Center.

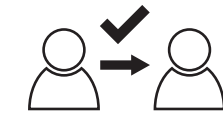

8. You will receive an acknowledgment/quotation, from Pfeiffer Vacuum.

PFEIFFER VACUUM

Our sales and delivery conditions and repair and maintenance conditions for vacuum devices and components apply to all service orders.



14 Accessories



View the [range of accessories for DigiLine](#) on our website.

14.1 Accessory information

Power supply packs

Power supply packs for wall- and standard rail mounting to supply power to DigiLine gauges

Accessories for RS-485

Cables and fasteners for creating an RS-485 field bus

Supply and interface cable

Cable in various lengths, for connecting to a Pfeiffer Vacuum power supply unit or a PC

Seals with centering ring and filter

Filter available in different pore sizes to protect the measuring system against contamination in the event of potential contaminating applications

14.2 Order accessories

Part number	Selection field
PT 348 105 -T	Terminal resistor for RS-485
PM 061 270 -X	Coupling M12 for RS-485
PT 348 132 -T	Power separator for RS-485
P 4723 010	Y-distributor M12 to RS-485
PM 061 207 -T	USB RS-485 converter
PT 348 106 -T	Plug M12 m 4-pin with screw clamps for DigiLine RS-485, for customer-specific cables
PT 348 163 -T	Mains power supply DigiLine, M12, 4-pin to TPS, 3 m
PM 061 283 -T	Interface cable, M12 m straight/M12 m straight, 3 m
PM 061 284 -T	Interface cable, M12 m straight/M12 m straight, 5 m
PM 061 285 -T	Interface cable, M12 m straight/M12 m straight, 10 m
PF 117 216 -T	Centering ring with sintered metal filter, pore size 20 µm, FKM/stainless steel, DN 16 ISO-KF
PT 120 132 -T	Centering ring with fine filter, pore size 4 µm, FKM/stainless steel, DN 16 ISO-KF
PM 061 344 -T	TPS 111, power supply pack 19" plug-in unit 3HU
PM 061 340 -T	TPS 110, power supply pack for wall/standard rail installation

Tbl. 11: Accessories

15 Technical data and dimensions

15.1 General

	mbar	bar	Pa	hPa	kPa	Torr mm Hg
mbar	1	$1 \cdot 10^{-3}$	100	1	0.1	0.75
bar	1000	1	$1 \cdot 10^5$	1000	100	750
Pa	0.01	$1 \cdot 10^{-5}$	1	0.01	$1 \cdot 10^{-3}$	$7.5 \cdot 10^{-3}$
hPa	1	$1 \cdot 10^{-3}$	100	1	0.1	0.75
kPa	10	0.01	1000	10	1	7.5
Torr mm Hg	1.33	$1.33 \cdot 10^{-3}$	133.32	1.33	0.133	1

$$1 \text{ Pa} = 1 \text{ N/m}^2$$

Tbl. 12: Conversion table: Pressure units

	mbar l/s	Pa m ³ /s	sccm	Torr l/s	atm cm ³ /s
mbar l/s	1	0.1	59.2	0.75	0.987
Pa m ³ /s	10	1	592	7.5	9.87
sccm	$1.69 \cdot 10^{-2}$	$1.69 \cdot 10^{-3}$	1	$1.27 \cdot 10^{-2}$	$1.67 \cdot 10^{-2}$
Torr l/s	1.33	0.133	78.9	1	1.32
atm cm ³ /s	1.01	0.101	59.8	0.76	1

Tbl. 13: Conversion table: Units for gas throughput

15.2 Technical data

Parameter		Value
Measuring range	CCT 361	1000 hPa /0.1 hPa
	CCT 362	100 hPa/1 × 10 ⁻² hPa
	CCT 363	10 hPa/1 × 10 ⁻³ hPa
	CCT 364	1 hPa/1 × 10 ⁻⁴ hPa
	CCT 365	0.1 hPa/1 × 10 ⁻⁵ hPa
Maximum pressure (absolute)	CCT 361	400 kPa
	CCT 362	260 kPa
	CCT 363	
	CCT 364	
	CCT 365	130 kPa
Burst pressure (absolute)		500 kPa
Gas type dependence		None
Precision ¹⁾	CCT 361	0.20 % of measured value
	CCT 362	
	CCT 363	
	CCT 364	
	CCT 365	0.50 % of measured value

1) Non-linearity, hysteresis, repeatable precision within calibrated range at 25 °C ambient temperature without influence of temperature after 2 hours of operation.



Parameter		Value
Temperature influence on zero point	CCT 361	0.0050% FS/ °C
	CCT 362	
	CCT 363	
	CCT 364	0.015 % FS/ °C
	CCT 365	0.020 % FS/ °C
Temperature influence on range	CCT 361	0.01% of measured value/ °C
	CCT 362	
	CCT 363	
	CCT 364	
	CCT 365	0.03 % of measured value/ °C
Resolution		0.003% FS
Gauge calibration		Button for zero point calibration

Tbl. 14: Measured and pressure values

Parameter		Value
Response time	CCT 361	60 ms
	CCT 362	
	CCT 363	
	CCT 364	
	CCT 365	
Supply voltage	at gauge	+14 to +30 V DC ²⁾
	Ripple	≤ 1 V _{pp}
Current consumption		< 500 mA (max. switch-on current)
Power consumption (dependent on supply voltage)		≤ 2.0 W
Internal fuse		1 AT (slow), automatic reset (Polyfuse)
Connection (electrical)		Binder M12 connector, 5-pole, A-coded
Measurement cable		4-pin, including shielding
Cable length		≤ 100 m
Grounding concept	Vacuum connection and signal earth	Connected via 1 MΩ (voltage difference < 18 V)
	Supply earth and signal earth	routed separately for differential measurement (10 Ω)

Tbl. 15: Electrical data

Parameter	Value
Protocol	ASCII, addressable (RS-485), Pfeiffer Vacuum protocol
Data format	Bidirectional data traffic, 1 start bit, data word length 8 bits, 1 stop bit, no parity bit, no handshake
Baud rate	9600
Connection	Binder M12 connector, 5-pole, A-coded

Tbl. 16: RS-485 interface

2) The gauge is protected against polarity reversal of the supply voltage.

Parameter	Value
Internal volume	≤ 4.2 cm ³
Weight	≤ 700 g

Tbl. 17: Internal volume and weight

Parameter	Value
Relative humidity	max. 80 % for temperatures up to +31 °C, reducing to 50 % at +40 °C
Mounting orientation	Arbitrary
Usage	Only in indoor areas
Installation altitude max.	2000 m MSL
Protection degree	IP40

Tbl. 18: Ambient conditions

Parameter	Value
Operation	+5 to +50 °C
Bake out (not operational)	≤ 110 °C at flange
Bearing	-40 to +65 °C

Tbl. 19: Temperatures

Parameter	Value
Flange, tube	Stainless steel AISI 316L
Sensor, diaphragm	Aluminum oxide ceramic (Al ₂ O ₃ ≥ 99.5%)
	Glass ceramic solder
	AgTiCu braze
	Vacon 70 (28% nickel (Ni), 23% cobalt (Co), 49% iron (Fe))

Tbl. 20: Substances in contact with the media

15.3 Dimensions

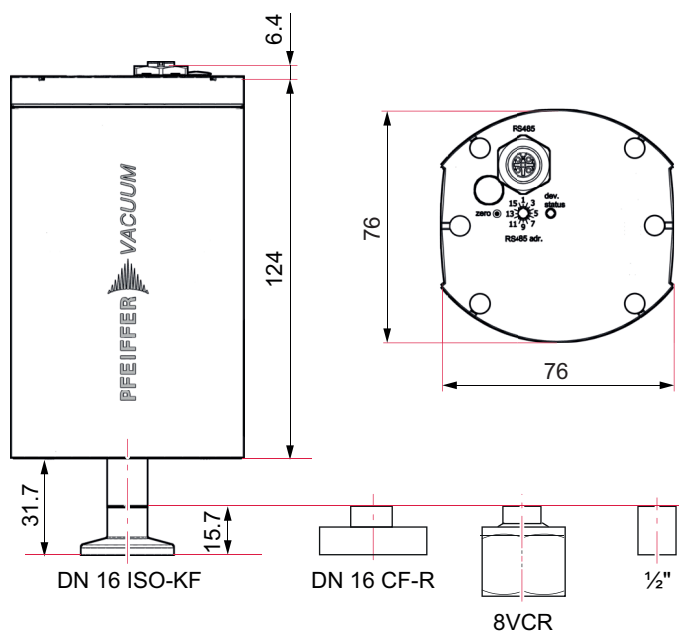

Fig. 8: Dimensions
Dimensions in mm



Declaration of conformity

Declaration for product(s) of the type:

Digital capacitive gauge

CCT 361
CCT 362
CCT 363
CCT 364
CCT 365

We hereby declare that the listed product satisfies all relevant provisions of the following **European Directives**.

Electromagnetic compatibility 2014/30/EU

Restriction of the use of certain hazardous substances 2011/65/EU

Restriction of the use of certain hazardous substances, delegated directive 2015/863/EU

Harmonized standards and applied national standards and specifications:

DIN EN 61000-6-2:2005
DIN EN 61000-6-3:2007 + A1:2011
DIN EN 61010-1:2010
DIN EN 61326-1:2013, group 1, class B

Signature:



(Daniel Sälzer)
Managing Director

Pfeiffer Vacuum GmbH
Berliner Straße 43
35614 Asslar
Germany

Asslar, 2020-10-22



VACUUM SOLUTIONS FROM A SINGLE SOURCE

Pfeiffer Vacuum stands for innovative and custom vacuum solutions worldwide, technological perfection, competent advice and reliable service.

COMPLETE RANGE OF PRODUCTS

From a single component to complex systems:

We are the only supplier of vacuum technology that provides a complete product portfolio.

COMPETENCE IN THEORY AND PRACTICE

Benefit from our know-how and our portfolio of training opportunities!

We support you with your plant layout and provide first-class on-site service worldwide.

ed. - - Date 2011 - P/N:BG6011BEN



Are you looking for a
perfect vacuum solution?
Please contact us

Pfeiffer Vacuum GmbH
Headquarters • Germany
T +49 6441 802-0
info@pfeiffer-vacuum.de

www.pfeiffer-vacuum.com

PFEIFFER  **VACUUM**

